

KOMATSU®

WB97S-5

NET POWER
74 kW / 99,2 HP @ 2.200 rpm

OPERATING WEIGHT
8.150 kg

WB
97S-5

4 WHEEL STEERING
BACKHOE LOADER



WB97S-5

WALK-AROUND

Tradition and innovation

The WB97S-5 belongs to the latest generation of Komatsu 4 wheel steering backhoe loaders, which comes to market with a number of innovations. It has been developed with constant attention to the needs of customers from all over the world. The result is a user-friendly machine that offers top class performance.

COMFORT

The result of extensive ergonomics testing is an outstanding level of comfort that allows the operator to work in the best conditions – for example through the extremely comfortable, deluxe suspension seat.

PRECISION

With the new WB97S-5 total control is standard, thanks to Komatsu's hydraulic system and PPC backhoe controls.

VERSATILITY

Developed to deliver its best in every application, the WB97S-5 offers several possibilities for customisation to get a 'made-to-measure' machine whatever your requirements.



NET POWER

74 kW / 99,2 HP @ 2.200 rpm

OPERATING WEIGHT

8.150 kg

**P**ERFORMANCE

The WB97S-5 delivers high productivity, outstanding performance and great fuel economy, thanks to its 'Full Power Shift' transmission and long backhoe arm.

SAFETY

Perfectly in line with Komatsu style, the WB97S-5 includes several features to guarantee maximum safety for the operator.

VISIBILITY

Thanks to the wide glass surfaces the machine offers an excellent visibility in all directions for a total control of the surrounding area.

STRONG POINTS



ABSOLUTE CONTROL

PPC servo-controls are standard for the front loader and backhoe. The backhoe joysticks are mounted on two independently adjustable columns and ensure excellent control. The multifunction joystick for the loader includes the controls for the 4x1 bucket, declutch and speed-up function. PPC controls are also standard for the rear vertical stabilisers.

OPERATOR'S ENVIRONMENT

With its ROPS and FOPS structure, the cab has a modern design and is fully equipped. Its increased internal volume and wide, round glass surface offer great operator comfort. The spacious design optimises the ventilation system and optional air condition system, which include several conveniently located vents. The De-Luxe suspension seat, a complete instrumentation, an easy-to-reach control panel and plenty of holders and storage compartments make this machine the best in its class. To further increase safety, all machines are equipped with the SPS (Seat Position Switch), a patented device which disengages the PPC backhoe controls in case of accidental movements.



HYDRAULIC SYSTEM

The WB97S-5 offers high productivity and top performance with increased breakout force and lifting capacities. The heart of the Komatsu backhoe loader hydraulics is the CLSS (Closed Load Sensing System). Thanks to its variable flow, the system efficiently supplies the power the machine requires as it is needed. With two working modes, 'Power' and 'Economy', the operator can conveniently choose between maximum power and minimum fuel consumption.





BACKHOE

The rounded shape of the backhoe enhances the loading capacity of the machine and its ability to overcome obstacles. To maximise the operator’s excavating experience, standard PPC controls ensure extremely smooth and precise movements. The long arm delivers excellent digging ability. The telescopic arm and off-set boom, together with a wide range of attachments, significantly increase the machine’s versatility.

4 WHEEL STEERING

It’s possible to select 3 steering modes: 2 wheel steering (for standard BHL operation), 4 wheel steering (for agile and fast operation) and crab (for confined areas). This ensures great versatility and outstanding manoeuvrability. It’s easy and safe to change the steering mode: just push 2 switches at the same time on the new panel, and a green lamp will inform you about the steering mode selected. The WB97S-5 is equipped with 4 equal size wheels to guarantee better weight distribution and more traction.



TRANSMISSION

The ‘Full Power Shift’ transmission is controlled by a twist grip lever, with automatic gear shifting as standard. Indicator lights on the front dashboard show if the automatic mode is selected or which gear is engaged. A ‘kick-down’ function is also fitted as standard, allowing sequential shifting from 2nd gear to 1st (and vice versa) just by pressing a switch. The limited slip differential and ‘Heavy Duty’ axles increase efficiency and agility under any conditions. The multi-disk hydraulic brakes are self-adjusting. They can be activated by two independent pedals to guarantee maximum safety and high manoeuvrability.

SPECIFICATIONS



LOADER

The design of the front loader allows excellent parallelism when lifting and lowering the bucket. Furthermore, thanks to the linkage geometry, the greasing points have been reduced.

Standard bucket width.....	2.420 mm
Standard bucket capacity (ISO 7546).....	1,1 m ³
STD bucket weight.....	450 kg
Lifting capacity	
at maximum height.....	3.820 daN (3.900 kg)
Lifting capacity	
at ground level (ISO 8313).....	5.195 daN (5.300 kg)
Breakout force (ISO 8313).....	6.383 daN (6.500 kg)
4x1 bucket width.....	2.440 mm
4x1 bucket capacity (ISO 7546).....	1,03 m ³



SERVICE CAPACITIES

Engine oil.....	12,8 l
Cooling system.....	16,5 l
Diesel tank.....	150 l
Hydraulic oil tank.....	41 l
Hydraulic oil system capacity.....	97 l
Front axle oil.....	13 l
Rear axle oil.....	13 l
Gearbox oil.....	16 l



BACKHOE

The boom has a reinforced structure and allows 180° rotation, still preserving high torque. The casted swing support and arm ends ensure high fatigue resistance. Vertical outriggers with adjustable wear device.

Bucket breakout force (ISO 6015).....	5.980 daN (6.100 kg)
Arm breakout force (ISO 6015).....	3.920 daN (4.000 kg)

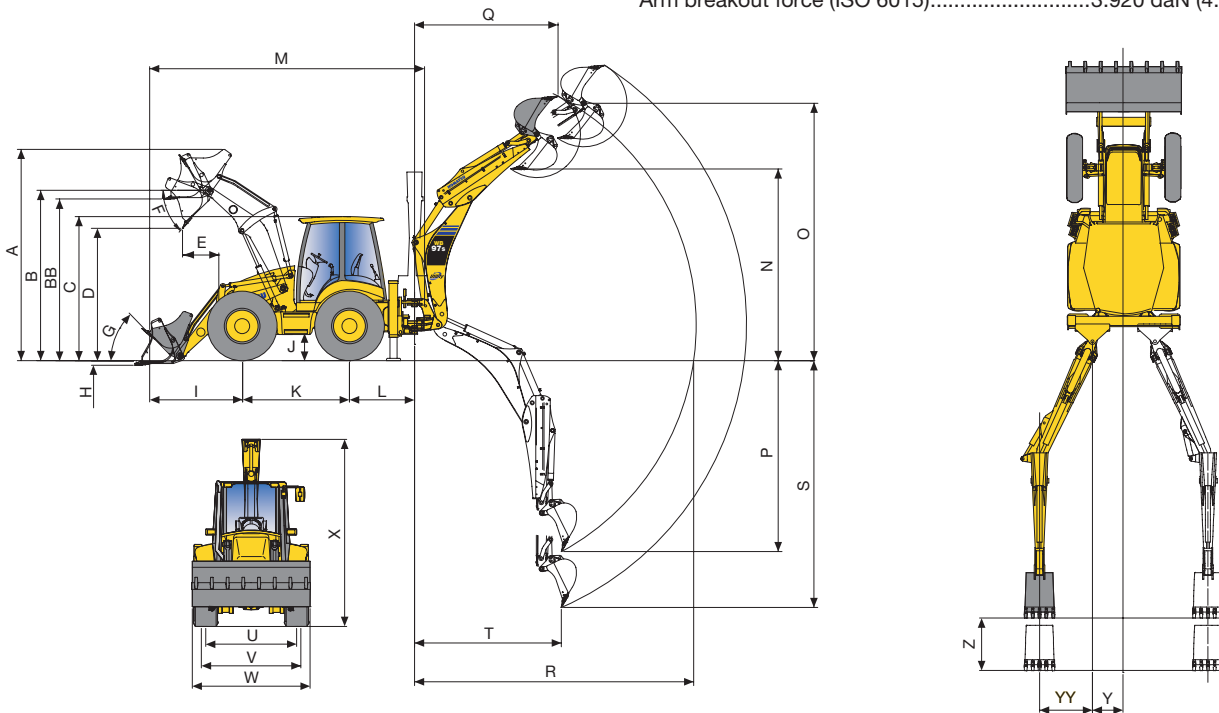

A. max height.....	4.290 mm
B. pin height.....	3.375 mm
BB. forks loading max height.....	3.175 mm
C. cab height.....	2.830 mm
D. max dumping height.....	2.720 mm
E. max dumping reach (45°).....	700 mm
F. dumping angle.....	45°
G. rollback angle.....	45°
H. digging depth.....	130 mm
I. bucket reach (in transport).....	1.930 mm
J. ground clearance.....	440 mm
K. wheel base.....	2.215 mm
L. backhoe swing centre distance.....	1.320 mm
M. transport length.....	5.895 mm
N. dumping height SAE.....	4.000 mm
max dumping height.....	4.385 mm
- with extended telescopic SAE.....	4.675 mm
- with extended telescopic max.....	5.148 mm
O. max digging height.....	6.015 mm
- with extended telescopic.....	6.675 mm

P. digging depth SAE.....	4.840 mm
- with extended telescopic.....	6.080 mm
Q. reach at max height.....	3.045 mm
- with extended telescopic.....	4.235 mm
R. max reach from swing centre.....	6.035 mm
- with extended telescopic.....	7.175 mm
S. max digging depth.....	5.290 mm
- with telescopic.....	6.465 mm
T. digging reach.....	2.320 mm
U. rear tread.....	1.800 mm
V. front tread.....	1.934 mm
W. overall width (with bucket).....	2.320 mm
X. transport hoe height.....	3.710 mm
- with telescopic.....	3.780 mm
Y. side shift.....	605 mm
YY side shift with off-set.....	1.080 mm
Z. telescopic stroke.....	1.240 mm

BACKHOE LOADER

STANDARD EQUIPMENT

- | | | | |
|--|---|--|--|
| <ul style="list-style-type: none"> • Komatsu Stage 2 Turbo engine • Power Shift transmission with Automatic shifting and kick-down • Load Sensing, variable displacement axial piston pump • Side by side radiator • 4 wheel drive • De-Luxe mechanical suspension seat • Limited slip differential on both axles • 4 wheel steering (3 modes) with electronic alignment • Front mudguards • Declutch switch • Foot pedal and hand control accelerator • Horn • Maintenance free battery 160 Ah | <ul style="list-style-type: none"> • 12 V external electric plug • 12 V internal electric plug • Antifreeze (-36 °C) • Front and rear working lights • Road homologation • Lights for road travel • Rotating beacon • External Rear view mirrors • Internal rear mirror • ROPS/FOPS cab with heater and fan • Tinted glass • Adjustable steering column • Adjustable seat with safety belt • Front and rear washer and windshield wipers • Internal storage compartments (two lockable) • Cup-holder • Sun visor | <ul style="list-style-type: none"> • Radio pre-setting • Fully opening bonnet • External lockable toolbox • Dry type air cleaner with clogging indicator • Fuel filter with integrated water separator • Gauges & Indicators: transmission oil temperature, 4WD engagement, brake oil level, fuel level, hour meter, preheating, engine speed, engine coolant temperature, air filter clogging, engine oil pressure, steering mode, wheels alignment • Safe Position seat sensor • PPC servo-control for stabilisers • PPC lock switch • Tyres 16.9 × 28 - 12 PR | <p>LOADER</p> <ul style="list-style-type: none"> • PPC servo-control • Speed-up function • Heavy duty safety bar • Self-levelling • General purpose bucket with standard teeth <p>BACKHOE</p> <ul style="list-style-type: none"> • PPC servo-control • Power/Economy working modes • Electro-hydraulic backhoe boom lock • Backhoe swing transport lock • Electro-hydraulic backhoe slide frame release lock • Hydraulic cushions |
|--|---|--|--|

OPTIONAL EQUIPMENT

- | | | | |
|--|--|---|--|
| <ul style="list-style-type: none"> • Air conditioning • Additional front counterweights (170 kg, 375 kg) • De-Luxe pneumatic suspension seat • Drive shaft guard (front) • Cold area arrangement (-30 °C) with 185 Ah battery and pre-heating systems • High ambient/altitude arrangement • TÜV + TBG version (20 km/h or 40 km/h) • Battery disconnection safety switch • Rubber pads for stabilisers • Hose burst valves: <ul style="list-style-type: none"> - loader arm - backhoe - stabilisers • Hydraulic biodegradable oil • Hydraulic hand hammer circuit • Hydraulic oil filter clogging indicator • Air cyclone pre-filter | <ul style="list-style-type: none"> • Fuel filling pump • Four additional working lights on cab • Radio • Backup alarm • Tyres: <ul style="list-style-type: none"> - 16.9 × 24 - 12 PR - 16.9 × R24 XM 37 - 16.9 × R28 XM 37 - 440/80 R28 <p>LOADER</p> <ul style="list-style-type: none"> • LSS (Load Stabiliser System) • Safety valve deactivation switch • Auxiliary hydraulic circuits: <ul style="list-style-type: none"> - floating function - floating function and "Return-To-Dig" - front auxiliary hydraulic circuit - additional front auxiliary hydraulic circuit (6 way valve) | <ul style="list-style-type: none"> • Attachments: <ul style="list-style-type: none"> - bolt-on cutting edge - cutting edge on teeth - 4×1 bucket with pre-setting for flip-over forks and angle opening indicator - flip-over forks on 4×1 bucket - hydraulic and mechanical quick hitch - forks (for quick hitch) - general purpose bucket (for quick hitch) - 4×1 bucket (for quick hitch) - dozer blade - snow blade - hand hammer <p>BACKHOE</p> <ul style="list-style-type: none"> • Alternative control pattern • Hydraulic side-shift • Auxiliary hydraulic circuits: | <ul style="list-style-type: none"> - hammer circuit - 2-way circuit for attachments (auger, tilting bucket) • Offset boom • Telescopic arm • Offset boom and telescopic arm • Attachments: <ul style="list-style-type: none"> - mechanical quick hitch (for std buckets) - full range of buckets (300 mm - 900 mm) - ditch cleaning bucket (1.400 mm) - ditch digging bucket (1.000 mm) - hydraulic hammer |
|--|--|---|--|



Manufacturer: Komatsu Utility Europe

Head Office · via Atheste 4 · 35042 Este (Padova) - Italy

Tel. +39 0429 616111 · Fax +39 0429 601000 · www.komatsueurope.com · utility@komatsu.it

Call the experts

KOMATSU®

Komatsu Europe International NV

Mechelsesteenweg 586
B-1800 VILVOORDE (BELGIUM)
Tel. +32-2-255 24 11
Fax +32-2-252 19 81
www.komatsueurope.com

WESS005200 04/2006

Materials and specifications are subject to change without notice.

KOMATSU® is a trademark of Komatsu Ltd. Japan.