

macchine edili ed agricole
d DIECI

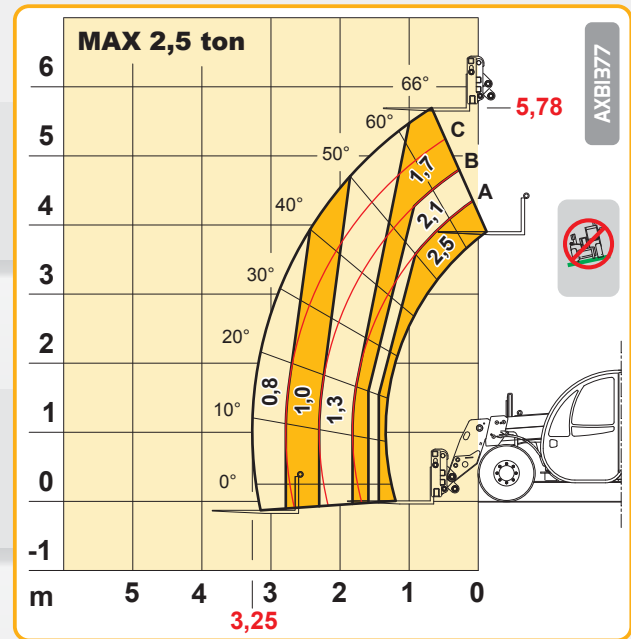

Apollo 25.6

Apollo 25.6

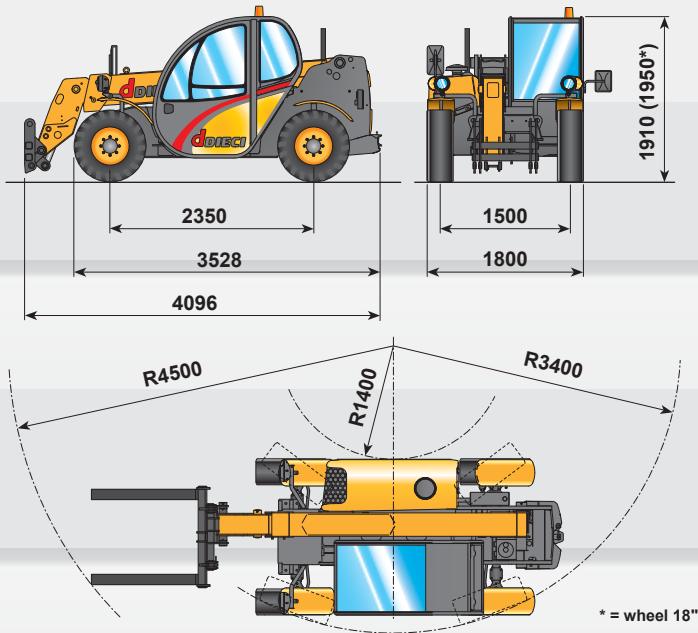

PERFORMANCES

Maximum capacity:	2.500 kg
Capacity at maximum height on tyres:	1.700 kg
Capacity at maximum boom extension on tyres:	800 kg
Maximum lifting height on tyres:	5,78 m
Maximum horizontal boom extension:	3,25 m
Boom extension at maximum height:	0,67 m
Fork tilting angle:	129°
Towing force:	4.400 daN
Maximum allowable slope:	40 %
Total empty weight:	4.800 kg
Max speed:	26 km/h *



ENGINE

YANMAR 4TNV98 - 52 kW ENGINE

Maximum power:	52 kW (71 hp) at 2500 rpm
Type, injection:	four-stroke diesel engine, direct
Cylinder number and layout:	4, vertical in line
Displacement:	3319 cm ³
Cooling system:	liquid

YANMAR 4TNV98T - 62.5 kW ENGINE

Maximum power:	62.5 kW (85 hp) at 2500 rpm
Type, injection:	four-stroke diesel engine, direct
Cylinder number and layout:	4, vertical in line
Displacement:	3319 cm ³ - Turbo compressor
Cooling system:	liquid



TRANSMISSION

Transmission:	Hydrostatic with variable delivery pump
Hydraulic engine:	with automatic adjustment
Reversing gear:	electro - hydraulic
Inching pedal for controlled forward movement.	



REFUELLING (litre)

Hydraulic tank:	70
Fuel tank:	80



HYDRAULIC SYSTEM

Gear pump with capacity at max speed:	80 lt/1'
Max working pressure:	200 bar
Control valve with joystick:	3 in 1



STANDARD DEVICES

Anti-tipping device with block for hazardous movements.
Hydraulic socket for possible accessories on boom head.
Closed soundproof ROPS - FOPS approved driver's cab, with heating.
Self-locking differential on front axle.



DIFFERENTIAL AXLES

Steering axles:	2, with 4 planetary reduction gears
Type of steering:	4 wheels/transversal/2 wheels
Front axle:	rigid
Rear axle:	oscillating
Service brake:	oil bath on the front axle
Negative parking brake.	



TYRES

Tyres:	12 - 16.5
Alternative:	12.0/75 - 18



OPTIONAL AND ACCESSORIES

Optional and Accessories: see the relevant catalogue.

The information contained in this publication is merely indicative; the models described may be modified, without notice, by the manufacturer, drawings and photographs may refer to optional or particular equipment for other countries. For any further information, please contact DIECI premises at the address given below.