

KOMATSU

Utility

SK
815-5



SK815-5

SK815-5

SKID STEER LOADER

NET POWER
SAE J1349
34,7 kW

OPERATING WEIGHT
2.630 kg

OPERATING CAPACITY
700 kg

NEXT GENERATION

Designed not only to do the work required, but to do it effectively and efficiently. Safe, environmental-friendly constructed employing state-of-the-art technology, the SK815 will help improve our environment in the twenty-first century.

Tradition in innovation

The new compact loader is the result of the skills, technology and success that KOMATSU has acquired in over eighty years of experience, and of its constant contact with users from all over the world during the product development phases.

Hydraulic servocontrols

Easier to use, they require very little effort, while ensuring extremely precise manoeuvres.

Komatsu CLSS

The hydraulic system, which automatically combines force and speed, ensures perfect control over all movements. Double-adjustment travel pumps, with automatic power control device (A.P.C.) and axial piston engines with double travel speed, provide above-standard performance, ensuring exceptional versatility and rapidity. Maximum travel speed: 16 km/h
Maximum traction force: 3400 kg

Comfort

The ease of operation, just two steps to reach the seat, the ergonomic access and the ample space inside the cab assure maximum operating comfort and maximum visibility.





Safety

The wheelbase and axle distance ensure reduced tyre wear and balanced weight distribution, for safe operation on any ground. The low profile of the engine hood guarantees excellent visibility on rear part of the machine. A system of sensors on the safety bars and the seat prevents all movements if unauthorised manoeuvres are attempted, with a brake being automatically engaged on the transmission.

Instrumentation

The new concept KOMATSU-patented dashboard is mounted on the safety bar, and is always visible to the operator.

Versatility

The foot accelerator ensures greater control over power during operation. Ready for use with any equipment, the base version features an auxiliary hydraulic circuit with proportional control. The control pedal can also be locked in the maximum flow rate position.

Super Flow version

The Super Flow system increases the flow of oil available to the equipment, and features a draining system and electrical connections. The joysticks and proportional pedal make it possible to control all the system functions. A second hydraulic circuit is available for equipment that requires simultaneous movements.

Super Flow circuit max flow rate: 100 (90*) l/min

Second circuit flow rate: 62 (10*) l/min

* Flow rate for the combined operation of the 2 circuits.



Easy and quick maintenance

The simple opening of the engine hood makes refilling and periodical checks easy. In addition, the tilting radiators can be easily reached by simply opening the rear door. One lock only for the hood and the door, which together enclose and protect all service and refill points.

- Pins with extended greasing intervals (250 hours);
- Battery with charge gauge;
- Air filter with safety cartridge;
- Removable polyvinyl tank;
- See-through gas oil filter;
- Environmental-friendly draining systems.



Tilting cab

The combined tilting of the cab, engine hood and footboard (patented system) offers complete access to all the components and allows extraordinary maintenance operations to be performed from several positions.



SPECIFICATIONS



ENGINE

A new generation of engine developed to comply with the stricter emission controls (EURO 2).

ModelKomatsu 4D88E-1FD
 Typediesel engine, 4 in line cylinders
 Bore x stroke88x90 mm
 N° of cylinders 4
 Combustiondirect injection
 Aspirationnatural
 Max power37 kW
 Rated power:
 (SAE J1349)34,7 kW/47,2 HP - 2.800 rpm
 (80/1269/EC)34,0 kW/46,2 HP - 2.800 rpm
 Max Torque142 Nm - 1.800 rpm

Cooling system water
 Air filterdry with safety element
 Starting systemelectric motor with pre-heating air system for cold climate



OPERATING WEIGHT

Operating weight of machine with standard bucket, full tank of fuel and a 80 kg operator (ISO 6016)2.630 kg



HYDRAULIC SYSTEM

TypeKomatsu CLSS (Closed Load Sensing System)
 Pumpgear
 Max flow62 l/min
 Max pressure191 bar
 Control valve3 elements fully Servo-controlled

Front equipment hydraulic system "SUPER FLOW" (Optional):

Max flow100 l/min
 Max pressure191 bar
 Control valve3 or 4 elements



ELECTRIC SYSTEM

Rated voltage12 V
 Battery80 Ah
 Alternator40 A



CONTROLS

Proportional Servo-controls (PPC). The left hand lever controls the machine movements, the right one controls the working equipment. The PPC pedal controls the auxiliary circuit for attachments. A safety system neutralises all operations when the safety bars are risen or the operator is not seated.

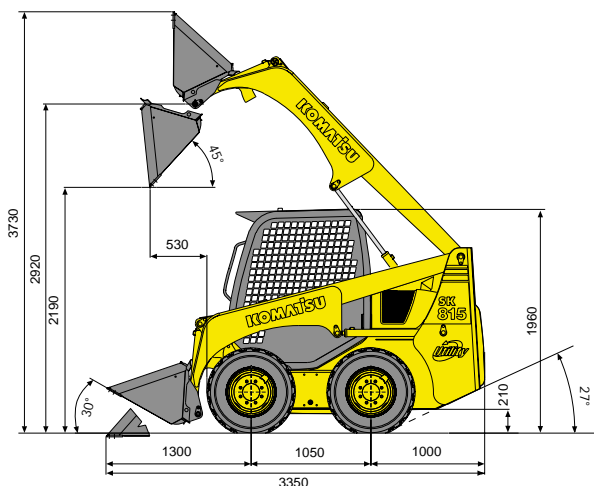

TRANSMISSION

Typehydrostatic
 Pumps2 x variable displacement with 2 stage and APC system

Motors2 x axial pistons with two speeds
 Final transmission with heavy duty type roller chains immersed in oil bath are always oil connected with the four driving wheels.

Speeds: - Working10,5 km/h
 - Travel16 km/h

Oil immersed discs for both parking and working breaks with negative action and automatic insertion.



TYRES

Standard10-16.5 8PR
 Optional10-16.5 8PR (narrow tread)
 10-16.5 (Airboss)
 31 x 15.5 -15 8PR



NOISE LEVEL

(Dynamic test)
 Sound power level test101 LwA dB(A)
 Sound pressure level86 LpA dB(A)
 The values inside and outside the cab are given according to the directive EC89/514 and EC95/27.



REFILLS

Hydraulic system38 /
 Fuel53 /
 Hydraulic transmission (chains)15,5 + 15,5 /
 Engine oil8 /



LOADER

Operating load (ISO 5998)700 kg
 Tipping load (ISO 8313)1.400 kg
 Standard bucket capacity (ISO 7546)0,4 m³
 Bucket breakout force (ISO 8313)1.716 daN (1.750 kg)
 Max lifting capacity (ISO 8313)2.138 daN (2.180 kg)
 Operating load with pallet forks490 kg
 Max loading height with forks2.720 mm
 Max reach with forks1.920 mm

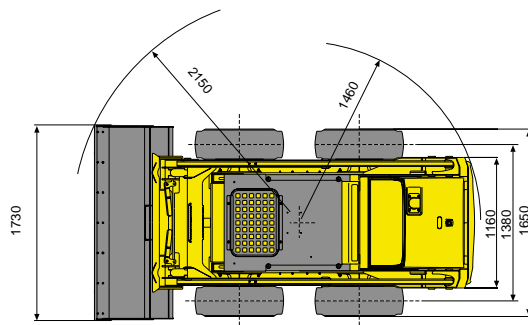

SK815-5 SKID STEER LOADER

STANDARD EQUIPMENT

- | | | |
|--|--|---|
| <ul style="list-style-type: none"> • ROPS-FOPS tilting cab • Adjustable seat with safety belts • Safety bars • 2 speed transmission • 2 front working lights • Instrumentation:
hour meter – LCD fuel level indicator – LCD water temperature indicator – safety warning lights : operator on board, safety bars | <ul style="list-style-type: none"> – other lights: air filter clogging, engine oil pressure, generator, hydraulic oil filter, engine pre-heating, parking brakes, second travelling speed, working lights, direction indicators, floating. • Automatic working and parking brakes • Horn • Accelerator pedal | <ul style="list-style-type: none"> • Bucket self leveling • Auxiliary hydraulic circuit for attachments • 12 V electrical plug outside • 10-16.5 8PR tyres • Quick hitch for attachments: Universal type or Komatsu type • 1.730mm bucket with or without teeth |
|--|--|---|

OPTIONAL EQUIPMENT

- | | | |
|--|--|---|
| <ul style="list-style-type: none"> • Bucket float • SUPER FLOW version with 3 elements main valve (with drain line and electric connection) • SUPER FLOW version with 4 elements main valve (with drain line and electric connection) with additional auxiliary hydraulic circuit for multifunctional attachments • Accessories for road homologation • Adjustable seat with safety belts • 10-16.5 8PR narrow tread tyres • 10-16.5 Airboss tyres • 31x15.5-15 8PR wide tyres | <ul style="list-style-type: none"> • 1.550mm bucket with or without teeth • 1.800mm bucket with or without teeth • Cutting edge on teeth • Bolted cutting edge (instead of teeth) • 2 rear working lights • Rotating beacon • Back-up alarm • Rear view mirrors • Pallet forks • Lifting hooks • Side windows • 12 V power outlet inside | <ul style="list-style-type: none"> • FOPS class 2 cab • Closed cab with glass sides, door with wiper and heater • Backhoe pre-setting • Rear hydraulic stabiliser • Backhoe pre-setting • Load stabiliser system (LSS) • Centrifugal air pre-filter • Master disconnect switch • Catalytic exhaust silencer • Mudguards • Additional modular rear counterweight (6 pieces, total 126 kg) |
|--|--|---|

KOMATSU

Komatsu Utility Europe

Head Office

via Atheste 4

35042 Este (Padova) - Italy

Tel. +39 0429 616111

Fax +39 0429 601000

www.komatsuequipmentcentral.com

utility@komatsu.it



COMPANY WITH
ENVIRONMENTAL MANAGEMENT
SYSTEM CERTIFIED BY DNV
ISO 14001