

KOMATSU

PC50MR-2

OPERATING WEIGHT

4.765 - 5.255 kg

ENGINE POWER

30,3 kW / 40,6 HP @ 2.350 rpm

BUCKET CAPACITY

0,07 - 0,175 m³

PC
50MR-2

MINI-EXCAVATOR



PC50MR-2

WALK-AROUND

Tradition and Innovation

The new compact mini-excavator is the product of the competence and the technology that KOMATSU has been acquiring for over the past eighty years. The project has been developed with a constant attention to the needs of customers from all over the world; the result is a user-friendly machine, which offers top class performance.

Performance

The new short tail PC50MR-2 supplies optimal power and digging speed in confined spaces: yards, road works, demolition works, sewers, wherever traditional machines cannot work. Sturdiness and excellent stability ensure safety and confidence in any condition.

Komatsu CLSS

The **CLSS (Closed Load Sensing System)** hydraulic circuit guarantees power, speed and perfect control to all movements, including the combined ones. The main feature of this system is the connection between two variable displacement pumps and the closed-centre circuit with load sensing, which allows operators to perform all movements with maximum efficiency, regardless of the load or the rpm.

These characteristics are highlighted by the hydraulic servo-controls, which are by far the easiest to use and require minimum efforts to perform extremely precise manoeuvres.

Comfort

Despite its compact size, the PC50MR-2 offers a comfort which has no equals: spacious cab, **PPC** proportional servo-controls for all movements, sliding door, gas spring assisted front window, storage drawer, hook, cup holder, courtesy lamp and, upon request, radio and air conditioning.

Versatility

Many available configurations allow the operator to choose the right machine for the specific job: short or long arm, cab or canopy, rubber or steel shoes, extra



OPERATING WEIGHT
4.765 - 5.255 kg

ENGINE POWER
30,3 kW / 40,6 HP @ 2.350 rpm

BUCKET CAPACITY
0,07 - 0,175 m³

counterweight.

Moreover, the 1 / 2 way auxiliary hydraulic circuit consents to use multiple working tools, like the hammer, the clamshell bucket, the auger, etc.

Maintenance

All periodic inspection points are easily accessible through the bonnets. The fuel and the hydraulic oil tanks are located under the side bonnet, in a safe and easy to reach position.



In addition, extra-ordinary maintenance can be performed by simply tilting the cab upwards: under the floor, the operator can find all major hydraulic components, like the main valve or the swing motor.

ORFS hydraulic face seal connectors and DT electric connectors improve the reliability of the machine and make repairs easier and faster.

Special technical solutions have allowed to extend up to 500 hours the intervals for most ordinary maintenance operations, such as pin greasing or engine oil replacement.

Also, to avoid possible leakage, all tanks are equipped with a draining hose: this confirms once again the attention KOMATSU pays to the environment.

OPERATOR'S ENVIRONMENT



The spacious cab has been developed with exceptional care for details, making the work environment noiseless and comfortable. Special attention has been paid to the internal layout: ergonomic and dedicated PPC controls; speed switch button on the panel instead of pedal, which consequently offers more floor room; adjustable seat; gas spring assisted front window opening; efficient heating and ventilation system. Air conditioning is upon request and guarantees optimal thermal comfort all year long.

Last, but not least, the upper rail type sliding door makes getting on/off the machine very easy and safe in any situation.

STRONG POINTS

Engine

The KOMATSU engine supplies the required power, keeping the fuel consumption very low. By taking advantage of state of the art technologies, it ensures minimum levels of noise and emissions (STAGE 2).



Automatic Shift Down

Once turned on, this device automatically adjusts the hydraulic travel motor to the working conditions: maximum displacement for faster movements, minimum displacement for top drawbar pull. This process doesn't require operator's support.



Attachment line

The 1 / 2 way auxiliary hydraulic circuit allows the use of several tools for different purposes: hammer, clamshell bucket, and so on. The switching between the two options is realised simply by means of a cock, which is located on the side of the machine and right behind a little bonnet.



X-Frame

The new casted type X-frame ensures maximum stress resistance and optimal stress distribution; this shape makes the machine much more rigid and reliable. In addition, it facilitates the usual undercarriage cleaning operations and the spoil removing.



Additional Counterweight

The opportunity to quickly add and remove counterweight allows conversion to the PC50MR-2 from *0-Tail* to *Short Tail* and vice-versa, thereby satisfying specific job-site requirements. Such counterweight increases the machine stability and the lifting capacity.



DIMENSIONS & WORKING RANGE

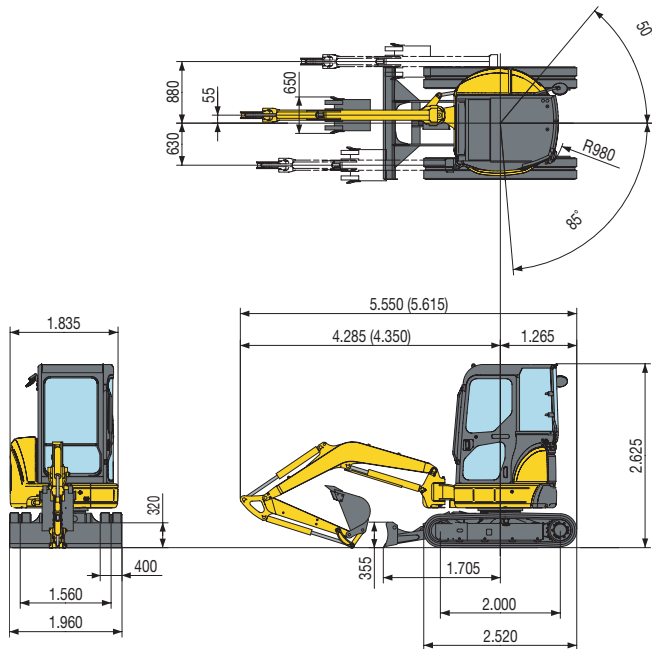

BUCKET RANGE			
Width mm	Capacity m ³ (ISO7451)	Weight kg	Teeth N.
300	0,07	75	2
400	0,1	90	3
500	0,125	100	4
600	0,15	115	5
700	0,175	125	5

Machine with Cab, Steel Shoes, Additional Counterweight and Blade at Ground Level

A - Distance from machine's center B - Height at bucket pin.

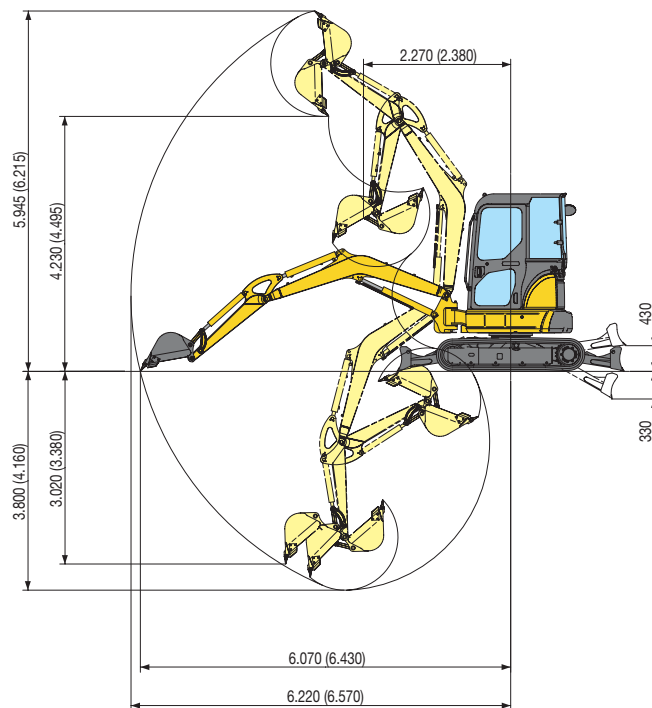

Arm length 1.640 mm								
B \ A	2 m		3 m		4 m		Max. outreach	
	Front.	360°	Front.	360°	Front.	360°	Front.	360°
3 m	/	/	/	/	(*) 805	(*) 805	(*) 835	590
2 m	/	/	(*) 1.330	(*) 1.330	(*) 1.025	880	(*) 880	525
1 m	/	/	(*) 1.995	1.295	(*) 1.295	840	(*) 935	505
0 m	(*) 1.590	(*) 1.590	(*) 2.325	1.240	(*) 1.480	810	(*) 1.005	520
-1 m	(*) 2.755	2.410	(*) 2.305	1.230	(*) 1.505	800	(*) 1.090	590
-2 m	(*) 3.480	2.455	(*) 1.980	1.245	(*) 1.275	810	(*) 1.190	770

Unit: kgf

Arm length 2.000 mm								
B \ A	2 m		3 m		4 m		Max. outreach	
	Front.	360°	Front.	360°	Front.	360°	Front.	360°
3 m	/	/	/	/	(*) 650	(*) 650	(*) 740	515
2 m	/	/	(*) 1.035	(*) 1.035	(*) 880	(*) 880	(*) 785	460
1 m	/	/	(*) 1.725	1.285	(*) 1.175	840	(*) 835	445
0 m	(*) 1.525	(*) 1.525	(*) 2.220	1.235	(*) 1.405	800	(*) 895	455
-1 m	(*) 2.375	2.365	(*) 2.320	1.210	(*) 1.500	780	(*) 970	505
-2 m	(*) 3.590	2.400	(*) 2.125	1.215	(*) 1.385	785	(*) 1.060	630

Unit: kgf

NOTE:

- Ratings are based on ISO standard 10567. Rated loads do not exceed 87% of hydraulic lift capacity or 75% of tipping load.
- The values marked with an asterisk (*) are limited by the hydraulic capacities - Calculations are based on the machine resting on a uniform and firm surface
- The lifting point is a hypothetical hook placed behind the bucket.

SPECIFICATIONS



ENGINE

The new generation engine has been developed to comply with the strictest emission controls (STAGE 2).

Model	Komatsu 4D88E-5
Type.....	emissionised 4-cycle diesel engine
Displacement.....	2.189 cm ³
Bore x stroke.....	88 x 90 mm
No. of cylinders	4
Combustion.....	direct injection
Aspiration	natural
Engine power	
at rated engine speed	2.350 rpm
ISO 14396.....	30,3 kW / 40,6 HP
SAE J1349	29,4 kW / 39,4 HP
Max. torque/engine speed	139 Nm @ 1.440 rpm
Cooling system.....	water
Air filter type	dry
Starting.....	electric motor with pre-heating air system for cold climate



SWING SYSTEM

The rotation is operated by means of an orbital hydraulic motor. Single ball-bearing ring with internal, induction hardened toothring. Centralised lubrication of the unit.
Swing speed.....9,0 rpm



TRANSMISSION

Type.....2 speed hydrostatic transmission, controlled and steered by means of two levers and two pedals
Hydraulic motors.....2 x axial pistons
Reduction system.....epicyclic reduction gears
Max. drawbar pull.....4.197 daN (4.280 kgf)
Travel speed.....2,8 - 4,6 km/h



BLADE

Type.....electro-welded, single unit structure
Width x height.....1.960 x 355 mm
Max. lifting above ground level.....430 mm
Max. depth below ground level.....330 mm



UNDERCARRIAGE

Central lower casted X-frame and carriage frame with boxed section.
Shoes (each side).....39
Track rollers (each side).....4
Shoe width.....400 mm
Ground pressure (standard).....0,29 kg/cm²



ELECTRIC SYSTEM

Voltage.....12 V
Battery.....72 Ah
Alternator.....40 A
Starter motor.....2,3 kW



SERVICE CAPACITIES

Fuel tank.....65 ltr
Radiator and system.....7,3 ltr
Engine oil.....7,4 ltr
Hydraulic system.....55 ltr



OPERATING WEIGHT

Operating weight with standard bucket, fully serviced, +75 kg operator (ISO 6016).
Operating weight with cab and rubber shoes.....4.940 kg
Operating weight with cab and steel shoes.....5.005 kg
Canopy.....-175 kg (optional)
Additional counterweight.....+250 kg



HYDRAULIC SYSTEM

Type.....Komatsu CLSS
Main pumps.....2 variable displacement pumps + 1 gear pump
Max. pump flow.....51 x 2 + 32 ltr/min
Max operating pressure:
 Working equipment.....27 MPa (270 bar)
Hydraulic motors:
 Travel.....2 x variable displacement
 Swing.....1 x fixed displacement
Hydraulic cylinders (bore x stroke):
 Boom.....90 x 697 mm
 Arm.....85 x 734 mm
 Bucket.....75 x 580 mm
 Boom swing.....95 x 630 mm
 Blade.....110 x 140 mm
Bucket breakout force (ISO 6015).....3.903 daN (3.980 kg)
Arm crowd force (ISO 6015):
 1.640 mm arm.....2.471 daN (2.520 kg)
 2.000 mm arm.....2.157 daN (2.200 kg)

The digging equipment is fully controlled by PPC servo-controls. All movements are stopped by lifting the safety levers on the tiltable case.

MINI-EXCAVATOR

STANDARD EQUIPMENT

- ROPS (ISO 3471) / FOPS (ISO 10262) tiltable cab with heating
- Sliding door
- Steel shoes
- Two speeds with "Automatic Shift Down"
- 1.640 mm digging arm
- 1 / 2 way auxiliary hydraulic circuit up to the boom
- Blade
- Adjustable suspension seat
- Lifting cylinder guard
- Working light on boom

OPTIONAL EQUIPMENT

- ROPS (ISO 3471) / FOPS (ISO 10262) tiltable canopy
- Rubber shoes
- 2.000 mm digging arm
- Additional counterweight
- Air conditioning
- Bucket range (300 - 800 mm)
- 1.400 mm ditch cleaning bucket
- Extension of the auxiliary hydraulic circuit up to the arm, with quick couplings
- Cocks for bucket cylinder
- Boom, arm and blade safety valves
- Overloading alarm
- Travel acoustic alarm
- Rotating beacon
- Biodegradable oil
- Rear mirrors
- Cab/canopy working lights
- Front and top protection guards



Manufacturer: Komatsu Utility Europe

Head Office · via Atheste 4 · 35042 Este (Padova) - Italy

Tel. +39 0429 616111 · Fax +39 0429 601000 · www.komatsueurope.com · utility@komatsu.it



Komatsu Europe International NV

Mechelsesteenweg 586
B-1800 VILVOORDE (BELGIUM)
Tel. +32-2-255 24 11
Fax +32-2-252 19 81
www.komatsueurope.com

WESS003103 01/2009

Materials and specifications are subject to change without notice.

KOMATSU is a trademark of Komatsu Ltd. Japan.